

Sproule Mfg. Co., Inc. ~ WeatherJac™

2 Segment - Installation Instructions

Step 1. Using the chart to the right, remove the required number of pieces from the box.

Type	Inside (Pink Label)	Outside (Green Label)
90° Elbow	2	2
45° Elbow	1	1

Step 2. Working in a watershed fashion, place an Inside (pink label) piece against the elbow. Be careful to center the alignment rib over the seam between the pipe covering and fitting cover as shown in Figure 1. If existing aluminum jacketing (not pictured) is covering the pipe covering/fitting cover seam, estimate the location of the seam.

Figure 1 Key

1. WeatherJac™ Inside (pink) piece
2. Fitting Cover
3. Pipe Covering
4. Pipe
5. Pipe Covering – Fitting Cover Seam
6. Alignment Rib
7. Inside Bead Detailed View

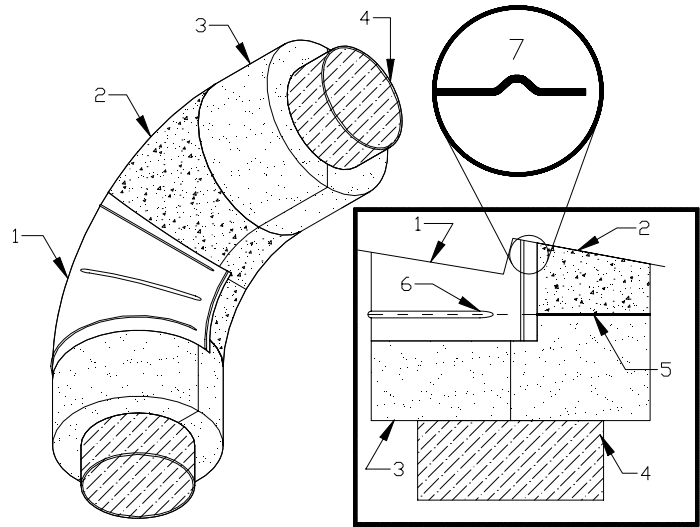

Figure 1 - Inside (Throat) Views

Step 3. Place an Outside (green label) piece on the opposite side of the fitting cover from the Inside (pink) piece. When placing the Outside (green) piece, ensure that the alignment ribs are in line with one another. The Outside (green) piece should overlap the Inside (pink) piece equally at the throat and the spine of the fitting cover.

Figure 2 Key

1. WeatherJac™ Inside (pink) piece
2. WeatherJac™ Outside (green) piece
3. Fitting Cover
4. Pipe Covering
5. Pipe
6. Pipe Covering – Fitting Cover Seam
7. Outside Bead Detailed View

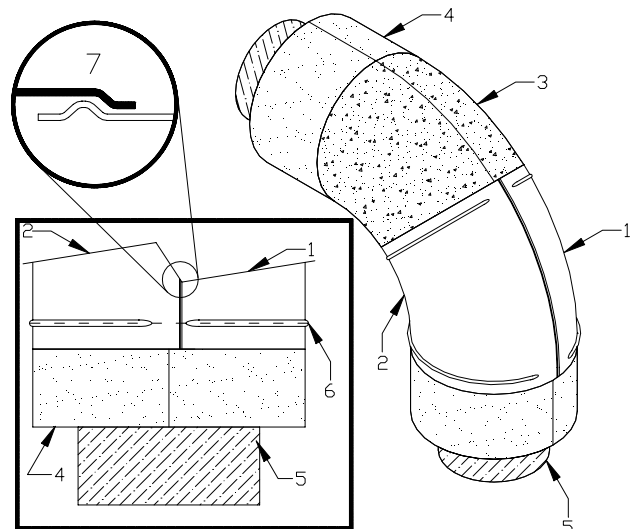

Figure 2 – Back (Spine) Views

Step 4. To ensure proper positioning of the WeatherJac™, slide the Outside (green) piece around the Insulation elbow until the overlap lies properly. If you find excess overlap in the throat (inside) of the fitting cover, slide the Outside (green) piece towards the spine (back) of the elbow. Overlap at the spine (back) is much easier to secure.

Figure 3 Key

1. WeatherJac™ Inside (pink piece)
2. WeatherJac™ Outside (green) piece

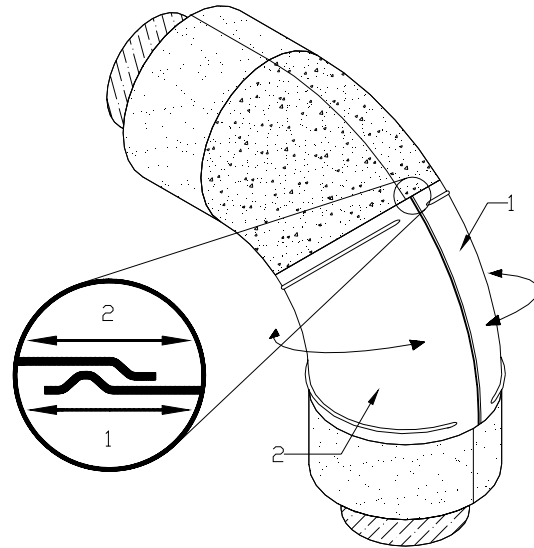

Figure 3

Step 5. Once positioned properly, temporarily tighten down the WeatherJac™ pieces with straps, Bungee™ cords, or wire ties. For hot service applications, permanently secure the WeatherJac™ with screws. Place the screws approximately 3/4" in from the edge of the Outside (green) piece, and on 3"-4" center along the spine (back) and throat (inside) of the elbow as shown in figure 4. Cold and dual-purpose applications should use straps and seal.

Note: If another section of WeatherJac™ pieces must be installed, do not place a screw within the 2"-3" of the alignment ribs. See step 6.

Figure 4 Key

1. WeatherJac™ Inside (pink piece)
2. WeatherJac™ Outside (green) piece
3. Temporary Strap, Bungee™ Cord, or Wire Tie

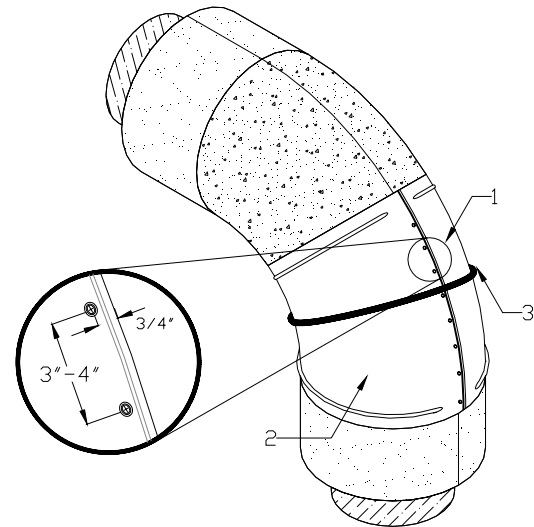

Figure 4

This completes the assembly of a WeatherJac™ 45° elbow.

Continue on to step 6 to complete a 90° elbow

Step 6. Still working in a watershed fashion, place the next Inside (pink) piece on the elbow, making sure the alignment ribs of the two inside pieces, seat over on another. To maintain a proper seal, tuck the corners of the new Inside (pink) piece under the corners of the previously installed Outside (green) piece as demonstrated in Figure 5.

Figure 5 Key

1. WeatherJac™ Inside (pink) piece
2. WeatherJac™ Outside (green) piece
3. Tuck the corners of the new Inside (pink) piece under the corners of the previously installed Outside (green) piece

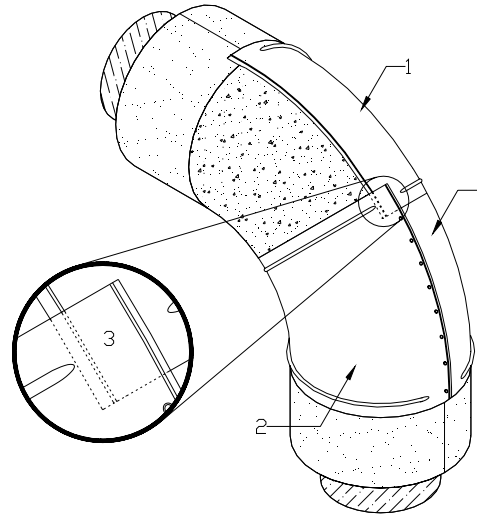

Figure 5

Step 7. Place the next Outside (green) piece on the elbow, again making sure to seat the alignment ribs directly over one another. Position and secure the WeatherJac™ as previously shown in steps 4 & 5.

Note: The alignment ribs must seat over one another to ensure a proper fit and seal.

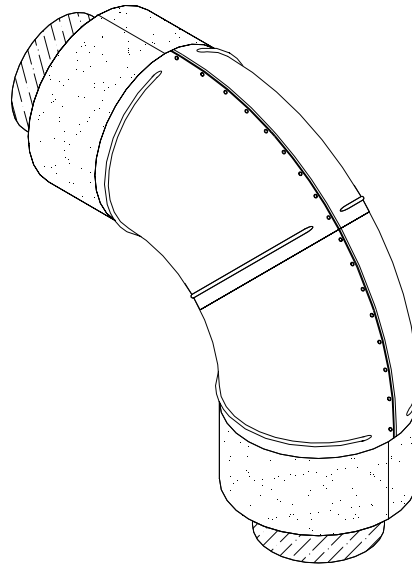

Figure 6

This completes the assembly of a WeatherJac™ 90° elbow.

If you have any additional questions, or have suggestions on how we can improve Sproule Mfg. Co., Inc. WeatherJacs™, please feel free to contact the factory at 1-800-628-6998.

The information herein is accurate and reliable to the best of Sproule Mfg. Co., Inc.'s knowledge. But, because Sproule Mfg. Co., Inc. has no control over our products once they leave our plant, no representation or warranty, expressed or implied, either as to Merchantability or Fitness for a particular purpose is made as to the performance or results of an installation containing our product which extend the description on the face hereof. If the products otherwise fail to conform to the representations made herein, through no fault of the purchaser, purchaser's exclusive remedy and Sproule Mfg. Co., Inc.'s sole liability, shall at Sproule Mfg. Co., Inc.'s option, be the repair or replacement of the nonconforming products or parts thereof, F.O.B. our nearest shipping point. The warranty expires one year from date of purchase. In no event shall Sproule Mfg. Co., Inc. be responsible or liable for any incidental, special or consequential damages, which might result from product failure.